

FLOOR DETAILS

FLOOR NOTES:

1. Use min. 2½" x 0.131" nails unless otherwise noted. Larger diameter nails might split flanges.
2. Fasten joists to top plate with at least two nails. Start nails at least 1½" from end to avoid splitting.
3. Engineered projects might require higher strength connections. Refer to designer's specifications.
4. 1¾" min. bearing at end supports. 3½" at intermediate and cantilever supports.
5. Framing lumber is assumed to be S-P-F unless otherwise noted.
6. See *Web Stiffener Requirements* on page 81.
7. Mid-span bridging is not required.

F1 END SUPPORT

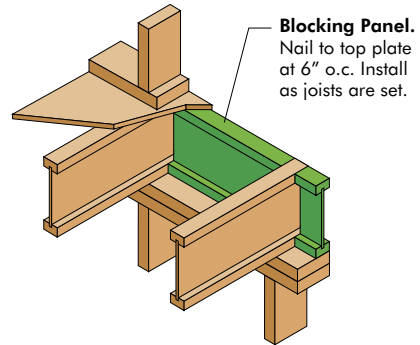

F2 END SUPPORT

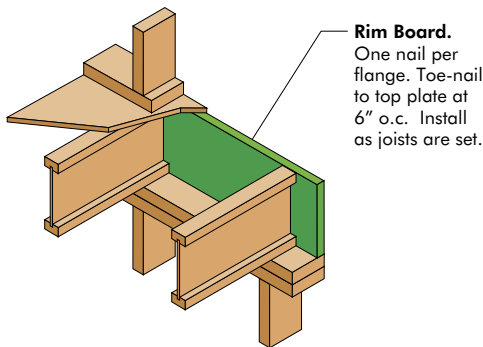

F3 END SUPPORT

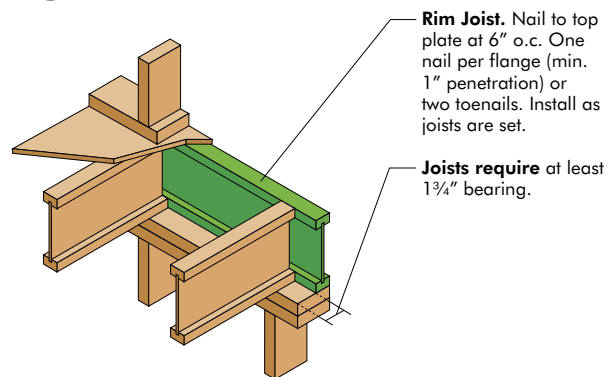

F4 INTERMEDIATE SUPPORT

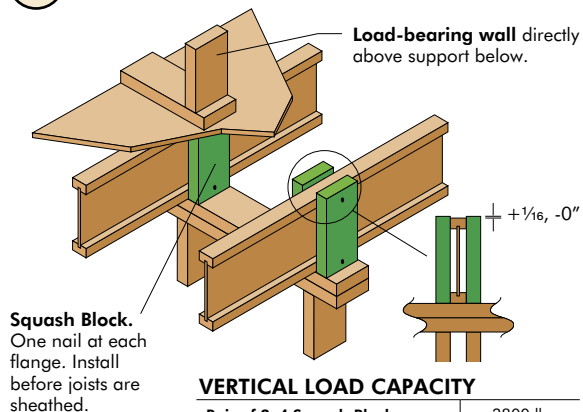

VERTICAL LOAD CAPACITY

Pair of 2x4 Squash Blocks	3800 lb
Pair of 2x6 Squash Blocks	5900 lb

(Hem-Fir wall plates assumed)

F5 AT COLUMNS

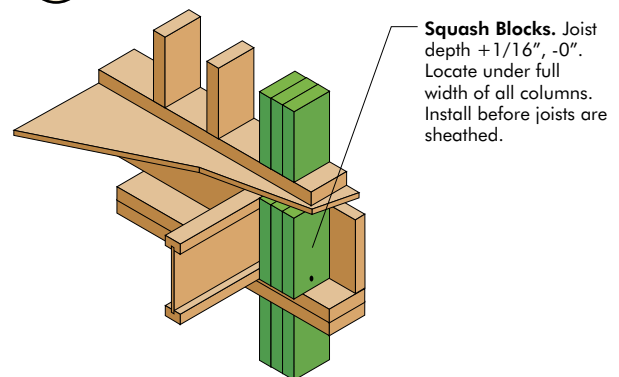

FLOOR DETAILS

F6 END WALL

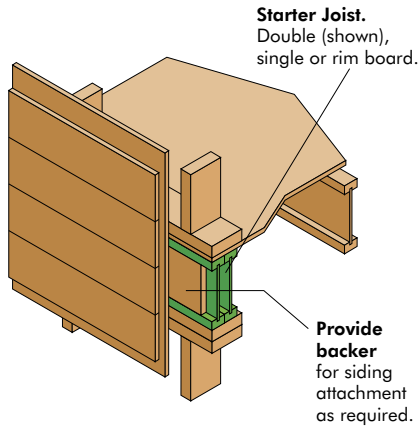

F7 INTERMEDIATE SUPPORT

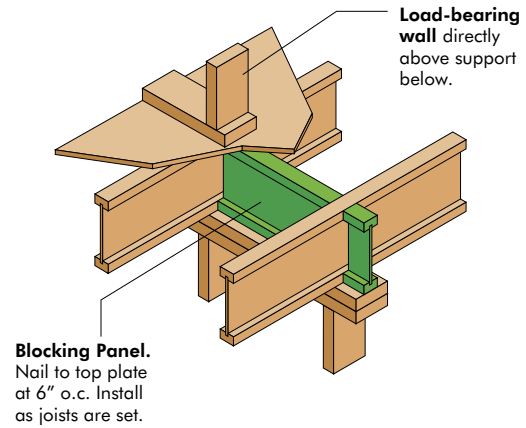

F8 FLOOR OPENING

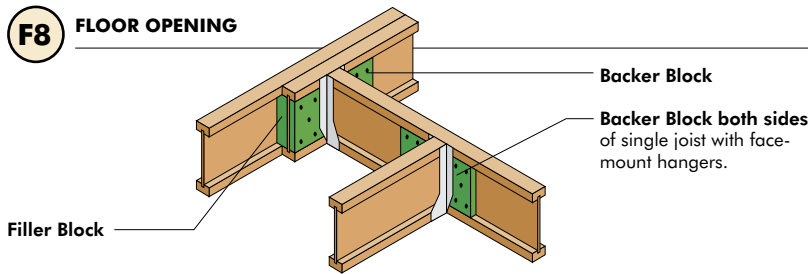

Notes:

1. Side Load is the concentrated load transferred by a joist hanger.
2. Use min. 0.131" diameter nails. For backer blocks, use 2 1/2" nails. For filler blocks, use length shown in table. Note that some joists require filler block nailing from each side.
3. Use Sheathing grade panels, Utility grade S-P-F lumber, or better. Thinner blocks may be combined to achieve specified thicknesses.
4. Size and position blocks to receive all nails, including hanger nails, without splitting.
5. Max. block depth is joist depth minus 3/8" to avoid an interference fit between flanges.
6. For top-mount hangers, install backer blocks snug to top flange.
7. Clinch nails when possible.
8. Attach hangers according to manufacturer's instructions.

Side Load	Backer Nails	Filler Nails
500 lb	8	4
750 lb	12	6
1000 lb	16	8
1250 lb	20	10
1500 lb	24	12
1750 lb	28	14
2000 lb	32	16

Joist Flange Width	Filler Block Nail Length	Filler Thickness	Backer Thickness
1 1/2"	2 1/2" min.	1 1/8" or 1 1/4"	1/2" or 5/8"
1 3/4"	3" min.	1 1/2"	3/4"
2 5/16"	3 1/4" min.	2"	1"
2 1/2"	3 1/2" min.	2" or 2 1/4"	1" or 1 1/8"
3 1/2"	3" min, each side	3"	1 1/2"

F9 AT WOOD BEAM

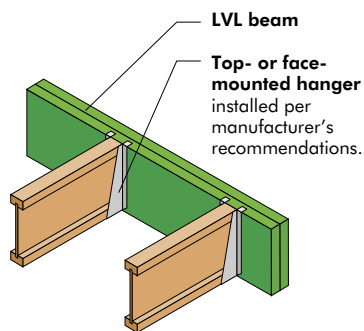

F10 AT MASONRY WALL OR STEEL BEAM

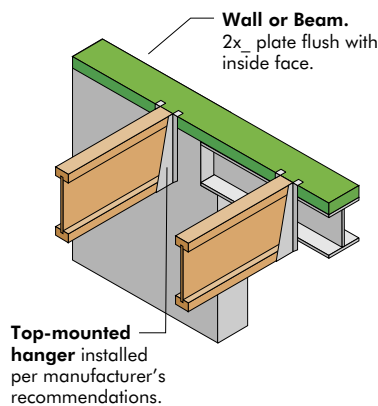

F11 BEVELED CUT

